

# MB 20

## MODBUS RTU LIITYNTÄYKSIKKÖ SAR 410:LLE

MB 20 on liityntäkortti painesäädin SAR 410:n liittämiseksi Modbus RTU väylään.

Luettavia ja ohjelmoitavia tietoja ovat huonesäätimen SAR sekä vetokaappisäätimien FHR ja näihin liittyneiden säätöpelten arvot.

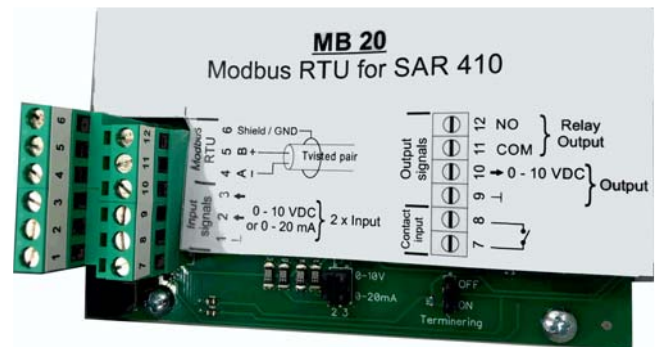

### TEKNISET TIEDOT

Käyttöjännite	24 VAC SAR 410 kautta
Tehonkulutus	2 VA
Ympäristön lämpötila	0 - 50 °C
Kotelointi	SAR 410 sisällä , IP 65
Liikennöinti nopeus	9600, 19200, 38400, 57600
Laiteosoitteet	1-247
Databitit	8
Stop-bitit	1 tai 2 ( 2 stop-bittiä jos pariteettia ei ole asetettu )
Pariteetti	Ei mikään/parillinen/pariton

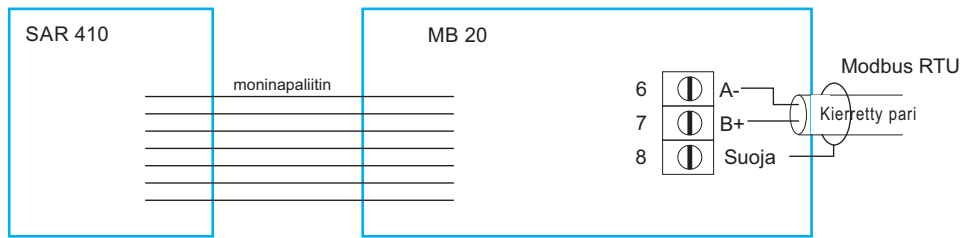

## TOIMINTAKUVAUS

MB 20 on SAR 410 huonesäätimen ja huoneväylään liitettyjen laitteiden liityntäyksikkö Modbus RTU väylälle.

## ASETUSTEN MÄÄRITTÄMINEN

Asetukset liikennöintinopeudelle, laiteosoitteelle ja pariteetille asetetaan erillisellä SAR 410:n ohjelmointilaitteella SAR ID 15 parametrilla.

ModBus-väylän päätyterminointi ja tuloviestien valinta tehdään piirikortilla olevilla jumbpereilla.

Analogisia viestiä liittimeen 2 ja 3 käytetään esimerkiksi analogisten säätöpeltilien asennon luentaan.

Tämä laitteen tietoturva on varmistettava kytkettävässä ModBus-verkossa.

## KYTKENTÄKAAVIO

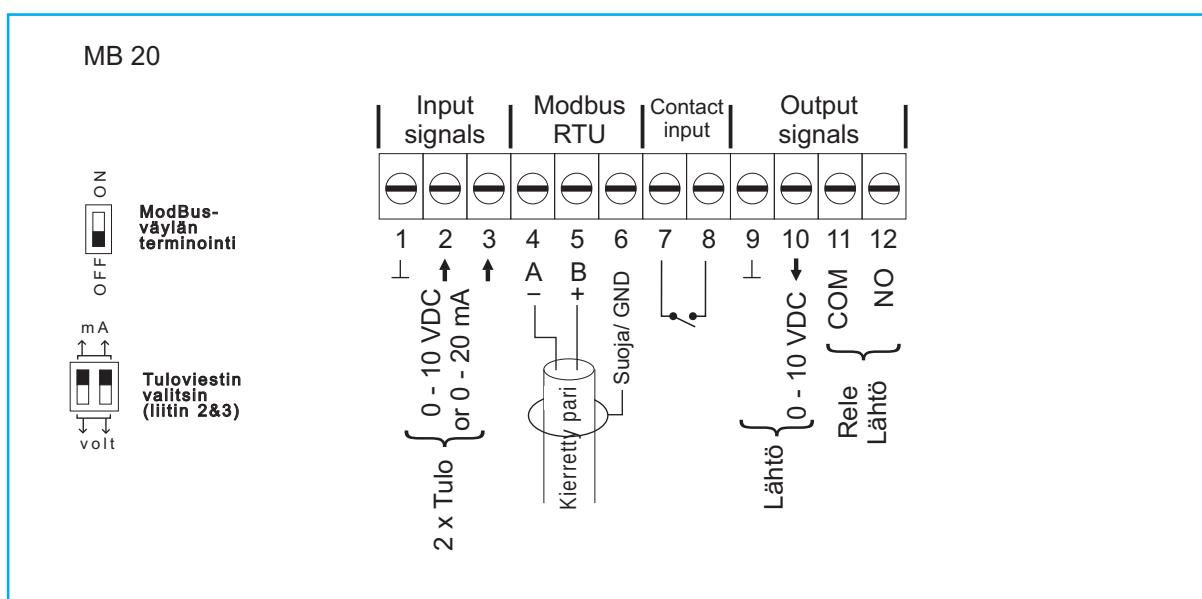

## Modbus rekisteri

### Modbus communication

**Interface:** RTU, RS-485  
**Baud rates:** 9600, 19200, 38400, 57600  
**Data bits:** 8 bits  
**Stop bits:** 1 or 2 (2 stop bits with no parity)  
**Parity:** None, Even, Odd

Slave address, baud rate and parity are changed in LabVent SAR Id 15

### Modbus function codes

Code	Description
03	Read Holding Registers
06	Write Single Holding Register

### Modbus exception codes

Code	Description
01	Illegal Function (for example if you try and write to a read-only register)
02	Illegal Address (if you try and read/write to an unmapped register)
06	Slave Device Busy (if you request external (FHR, ACU) registers too often)

### Modbus register mapping

SAR is mapped to holding registers 40001 - 40199.

FHR gets mapped to 40200 upto 42999 depending on the number of FHRs in the system.

ACU gets mapped to 43000 upto 44999 depending on the number of ACUs in the system.

Product	Reg Start	Reg End	Product	Reg Start	Reg End	Product	Reg Start	Reg End
SAR	40001	40199	FHR 22	42300	42399	ACU 1	43000	43099
FHR 1	40200	40299	FHR 23	42400	42499	ACU 2	43100	43199
FHR 2	40300	40399	FHR 24	42500	42599	ACU 3	43200	43299
FHR 3	40400	40499	FHR 25	42600	42699	ACU 4	43300	43399
FHR 4	40500	40599	FHR 26	42700	42799	ACU 5	43400	43499
FHR 5	40600	40699	FHR 27	42800	42899	ACU 6	43500	43599
FHR 6	40700	40799	FHR 28	42900	42999	ACU 7	43600	43699
FHR 7	40800	40899				ACU 8	43700	43799
FHR 8	40900	40999				ACU 9	43800	43899
FHR 9	41000	41099				ACU 10	43900	43999
FHR 10	41100	41199				ACU 11	44000	44099
FHR 11	41200	41299				ACU 12	44100	44199
FHR 12	41300	41399				ACU 13	44200	44299
FHR 13	41400	41499				ACU 14	44300	44399
FHR 14	41500	41599				ACU 15	44400	44499
FHR 15	41600	41699				ACU 16	44500	44599
FHR 16	41700	41799				ACU 17	44600	44699
FHR 17	41800	41899				ACU 18	44700	44799
FHR 18	41900	41999				ACU 19	44800	44899
FHR 19	42000	42099				ACU 20	44900	44999
FHR 20	42100	42199						
FHR 21	42200	42299						



## Modbus rekisteri / SAR Holding registers 40001-40164

SAR	HEADER	REG	DESCRIPTION	CMD	FORMAT	UNIT	FORMAT NOTE	MIN	MAX	DEF
1	Serial number	1	Serial number	03	u16			0	32000	500
2	Program version	2	Program version	03	u16		Ex: 123 = 1.23	0	65535	100
3	Analog input 1 (Air volume)	4	Range	03, 06	u16	l/s or m3/h	Unit is set in SAR register 67	0	4000	0
		5	Current value	03	u16	%		0	100	
4	Analog input 2 (Air volume)	7	Range	03, 06	u16	l/s or m3/h	Unit is set in SAR register 67	0	4000	0
		8	Current value	03	u16	%		0	100	
5	Analog input 3 (Air volume or room pressure)	10	Range	03, 06	u16	l/s or m3/h	Unit is set in SAR register 67	0	4000	0
		11	Current value	03	u16	%		0	100	
		13	Setpoint	03, 06	s16	Pa	Min and max depends on sensor type setting	-80	80	0
		15	Alarm level low	03, 06	s16	Pa	Min and max depends on sensor type setting	-100	100	-10
		16	Alarm level high	03, 06	s16	Pa	Min and max depends on sensor type setting	-100	100	10
6	Analog input 4 (air volume or room temperature)	17	Alarm delay	03, 06	u16	seconds		10	240	20
		19	Range	03, 06	u16	l/s or m3/h	Unit is set in SAR register 67	0	4000	0
		20	Current value	03	u16	%		0	100	
		21	Setpoint	03, 06	u16	Celsius		15	30	24
		22	Max control output	03, 06	u16	l/s or m3/h	Unit is set in SAR register 67	0	8000	0
7	Analog input 5 (Air volume or zone pressure)	23	Overtemperature	03, 06	u16	Celsius * 10	Celsius with 1 decimal point Ex 10 = 1.0 Ex 29 = 2.9	10	50	30
		25	Range	03, 06	u16	l/s or m3/h	Unit is set in SAR register 67	0	4000	0
		26	Current value	03	u16	%		0	100	
		27	Setpoint	03, 06	u16	Pa		100	400	200
		28	Manual control	03, 06	u16	%		0	100	50
8	Constant air or door switch	29	Alarm level	03, 06	u16	Pa		50	400	150
		30	Alarm delay	03, 06	u16	seconds		10	240	20
		34	Constant air 1 vol.	03, 06	u16	l/s or m3/h	Unit is set in SAR register 67	0	1000	0
9	Extra constant air	35	Constant air 2 vol.	03, 06	u16	l/s or m3/h	Unit is set in SAR register 67	0	1000	0
		36	Constant air 3 vol.	03, 06	u16	l/s or m3/h	Unit is set in SAR register 67	0	1000	0
10	Min. exhaust from room	37	Extra exhaust	03, 06	u16	l/s or m3/h	Unit is set in SAR register 67	0	8000	0
		38	Extra inlet	03, 06	u16	l/s or m3/h	Unit is set in SAR register 67	0	8000	0
11	Max. Exhaust from	39	Min. exhaust	03, 06	u16	l/s or m3/h	Unit is set in SAR register 67	0	8000	0
		40	Min. external exhaust	03, 06	u16	l/s or m3/h	Unit is set in SAR register 67	0	8000	0
15	Expansion module	53	Modbus address	03, 06	u16	1-247		1	247	1
16	Air balance	42	Max. exhaust	03, 06	u16	l/s or m3/h	Unit is set in SAR register 67	0	32000	0
		56	Adjust low	03, 06	s16	%		-100	100	0
		57	Adjust high	03, 06	u16	%		50	200	100
17	Total exhaust	58	Air balance	03, 06	s16	l/s or m3/h	Unit is set in SAR register 67	-3000	3000	0
		61	Total exhaust	03	u16	l/s or m3/h	Unit is set in SAR register 67			
18	Total inlet	62	Total inlet	03	u16	l/s or m3/h	Unit is set in SAR register 67			
19	Zone pressure	63	Zone pressure	03	u16	Pa				
20	Zone damper ang.	64	Zone damper ang.	03	u16	deg				
21	Room pressure	65	Room pressure	03	u16	Pa				
22	Temperature	66	Temperature	03	u16	Celsius				
		67	Global unit	03, 06	u16	0-1	0 = m3/h 1 = l/s	0	1	0
	Total nodes	68	Connected nodes	03	u16		Total number of nodes (FHR, ACU)			
		-	-	-	-	-	-	-	-	-
	MB20 Inputs / Outputs	70	Analog input 1	03	u16	%	Terminal block 2 on MB20	0	100	
		71	Analog input 2	03	u16	%	Terminal block 3 on MB20	0	100	
		72	Analog output 1	03, 06	u16	%	Terminal block 10 on MB20	0	100	0
		73	Digital input 1	03	u16	open,closed	Terminal block 7 & 8 on MB20	0	1	0
		74	Digital output 1	03, 06	u16	%	Terminal block 11 & 12 on MB20	0	1	0

Pidätämme oikeuden rajoittaa rekisterin kirjoitusoikeuksia. Start-up proseduriin liittyviä rekistereitä ei ole tässä esitetty.

Pidätämme oikeudet muutoksiin.



## Modbus rekisteri / FHR Holding registers 4xx00-4xx50 (xx=02...29)

FHR	HEADER	REG	DESCRIPTION	CMD	FORMAT	UNIT	FORMAT NOTE	MIN	MAX	DEF
		0	Connection status	03	u16	0-1	0 = OFFLINE 1 = ONLINE	0	1	0
1	Serial number	1	Serial number	03	u16					
2	Program version	2	Program version	03	u16		Ex: 123 = 1.23			
3	Setpoint	3	NORMAL	03, 06	u16	cm/s		30	150	50
		4	ECONOMY	03, 06	u16	cm/s		20	100	30
4	Anemometer (HPS 50)	5	Count	03, 06	u16			1	2	1
		6	Not for airvolume	03, 06	u16	0-1		0	1	0
		7	Mode	03, 06	u16	0-3	0 = Normal 1 = Normal Slow 2 = Analog 3 = Analog Slow	0	3	0
5	Alarm	8	Alarm level	03, 06	u16	%	Alarm level LED/Buzzer	20	90	80
		9	Delay LED	03, 06	u16	s		10	60	20
		10	Delay buzzer	03, 06	u16	s		10	60	20
		11	Buzzer reset	03, 06	u16	minutes OFF	0 = OFF	0	60	0
7	ECONOMY sensor	19	Count	03, 06	u16		Economy sensor, PD 30, IR 50, IR 60	0	2	1
		22	Onset delay	03, 06	u16	seconds		5	240	20
		23	Alarm sash high	03, 06	u16	cm or OFF	0 = OFF	0   10	50	0
10	Air limits	29	Min. air limit	03, 06	u16	(l/s or m <sup>3</sup> /h) OFF	0 = OFF Unit set in SAR register 67	0   100	1000	0
		30	Max. air limit	03, 06	u16	(l/s or m <sup>3</sup> /h) OFF	0 = OFF Unit set in SAR register 67	0   200	4000	0
		31	Max. air limit buzzer	03, 06	u16	0-1	0 = Not used 1 = Used	0	1	0
		32	Max. sash opening	03, 06	u16	cm OFF	0 = OFF	0   10	100	0
		33	Min. damper angle	03, 06	u16	deg		0	90	0
		34	Max. damper angle	03, 06	u16	deg		0	90	90
13	Sash pot. adjust	41	Sash pot. 1 adjust	03, 06	s16	cm	Signed integer	-10	10	0
		42	Sash pot. 2 adjust	03, 06	s16	cm	Signed integer	-10	10	0
14	Damper relation	43	FHD relation	03, 06	u16	%	FHD1 - FHD2 relation	50	200	100
15	Air flow adjust	44	Adjust low	03, 06	u16	%		50	200	100
		45	Adjust high	03, 06	u16	%		50	200	100
16	Damper 1	46	Damper 1 angle	03	u16	deg				
17	Damper 2	47	Damper 1 angle	03	u16	deg				
18	Air volume	48	Air volume	03	u16	l/s or m <sup>3</sup> /h	Unit set in SAR register 67			
19	Sash 1	49	Sash 1 height	03	u16	cm				
20	Sash 2	50	Sash 2 height	03	u16	cm				

## Modbus rekisteri / ACU Holding registers 4xx00-4xx11 (xx=30...49)

ACU.X	HEADER	REG	DESCRIPTION	CMD	FORMAT	UNIT	FORMAT NOTE	MIN	MAX	DEF
		0	Connection status	03	u16	0-1	0 = OFFLINE 1 = ONLINE	0	1	0
1	Serial number	1	Serial number	03	u16			0	32000	500
2	Program version	2	Program version	03	u16		Ex: 123 = 1.23	0	65535	100
4	Group	5	Controller mode	03, 06	u16	0-3	0 = Normal 1 = Normal Slow 2 = Analog 3 = Analog Slow	0	3	0
5	Alarm	6	Alarm level	03, 06	u16	%		20	90	80
		7	Alarm delay	03, 06	u16	s		10	60	20
6	Damper angle	8	Damper angle	03	u16	deg				
7	Air volume	9	Air volume	03	u16	l/s or m <sup>3</sup> /h	Unit is set in SAR register 67			
8	Air velocity	10	Air velocity	03	u16	cm/s				
9	Setpoint	11	Setpoint	03	u16	cm/s				

Pidätämme oikeuden rajoittaa rekisterin kirjoitusoikeuksia. Start-up proseduriin liittyviä rekistereitä ei ole tässä esitetty.

Pidätämme oikeudet muutoksiin.